

# Drainage device

for control panels & enclosures, IP66 / IP67 / IP69K



In enclosures and housings with a high degree of protection, temperature differences result in condensation. By using a drainage device, it is possible to safely drain off the condensate without losing a maximum enclosure protection of IP66. A water-permeable membrane ensures the drainage of the enclosure due to its capillary effect. The design prevents splash water from entering the interior of the enclosure.

The drainage device is fixed in the bottom of the enclosure using the union nut in a hole of  $\varnothing 50.5 +0.5$  mm. Make sure that the sealing ring is on the outer housing wall and that the hole is free of burrs.

IP66

IP67

IP69K

RoHS  
compliant

REACH  
COMPLIANCE

Made in  
Germany

## Specifications

<b>IP rating (EN 60529)</b>	IP66, IP67, IP69K
<b>Operating temperature</b>	-45 C° to 70 C°
<b>Mounting options</b>	Fasten with locknut

## Advantages & benefits

- High protection class IP66/67, IP69K
- Good drainage performance
- Easy assembly
- Based on a standard cut-out
- Sturdy, weatherproof and UV-resistant housing

## Product types & sizes

### Drainage device M50

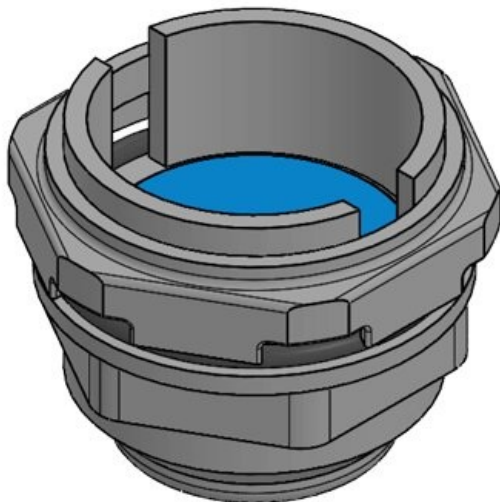

Part No.	<b>99193</b>	Cut-out size,	<b>50,5 mm</b>
EAN	<b>4251269324</b>	round	
	<b>789</b>	Thread	<b>M50 x 1,5</b>
Package quantity	<b>1</b>	Water permeability (5 mm water column)	<b>200 ml/h</b>
Length	<b>49,5 mm</b>		
Width	<b>60 mm</b>		
Height	<b>60 mm</b>		
Mounting height	<b>28,5 mm</b>		

